

Specification sheet LX 487

**Parapet roof drainage systems
Series 89 RAINSTAR®
with roof penetration of 55 mm**

Main drainage

Gravity flow

Silent

- Discharge rate:** 4,9 l/sec
- Water height:** 35 mm
- Roof penetration:** 55 mm
- Diameter:** DN 100
- LX-Number:** LX 487
- Weir height:** 0 mm
- Drain:** ventilated
- Downpipe:** not ventilated
- Downpipes height:** 4,2 m
- Entwässerung:** in sewer
- Flange form:** Clamping flange

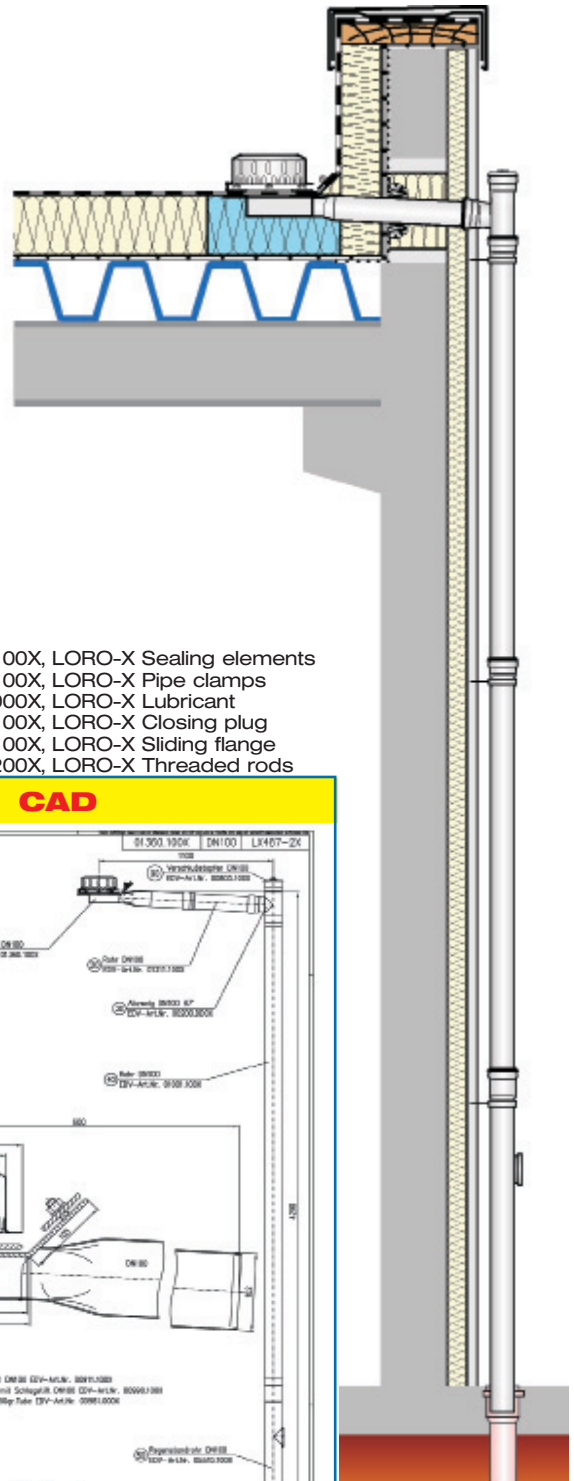

LX 487 Piece list

- 1 x Art.-No. choose drain on page two!**
- 1 x Art.-No. 01211.100X, LORO-X Pipe with one socket
- 1 x Art.-No. 00200.DD0X, LORO-X Branch
- 1 x Art.-No. 01001.100X, LORO-X Pipe with one socket
- 1 x Art.-No. 05510.100X, LORO-X Stand pipe

- 4 x Art.-No. 00911.100X, LORO-X Sealing elements
- 3 x Art.-No. 00975.100X, LORO-X Pipe clamps
- 1 x Art.-No. 00986.000X, LORO-X Lubricant
- 1 x Art.-No. 00805.100X, LORO-X Closing plug
- 1 x Art.-No. 13235.100X, LORO-X Sliding flange
- 3 x Art.-No. 09604.200X, LORO-X Threaded rods

hQ - Head-Discharge curve

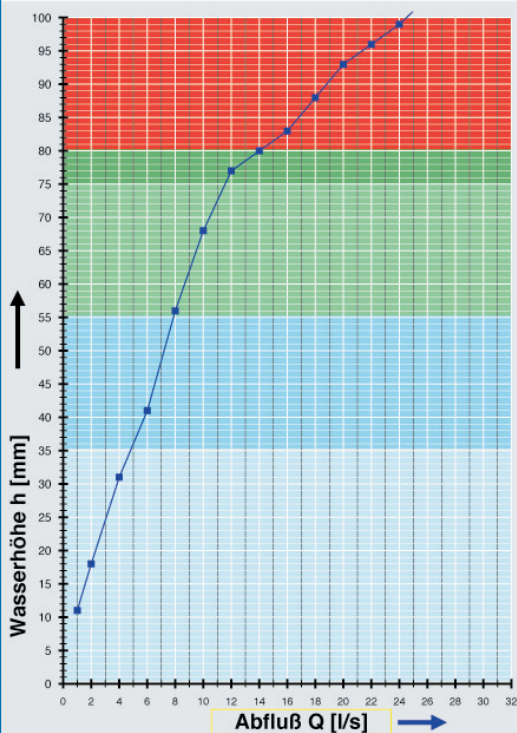

Systempower

CAD

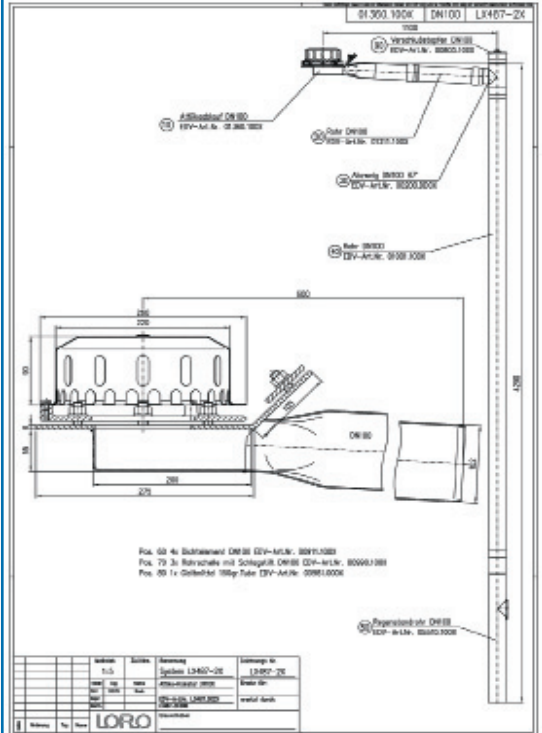

Systemshape

Water height	mm	5	10	15	20	25	30	35	40	45	50	55	60	65	70	75
Discharge	l/sec			1,5	2,2	3,0	3,9	4,9	5,8	6,5	7,2	7,9	8,6	9,5	10,5	
		Silent				Silent Power			Power							

Choose drain for piece list on page one!

DN 100

LX487-1X
 Drain Art.-No. 01362.100X
 Weight: 9,4 kg

Series 89
with roof penetration of 55 mm
 clamping flange 90°
 for plastic roofing sheets

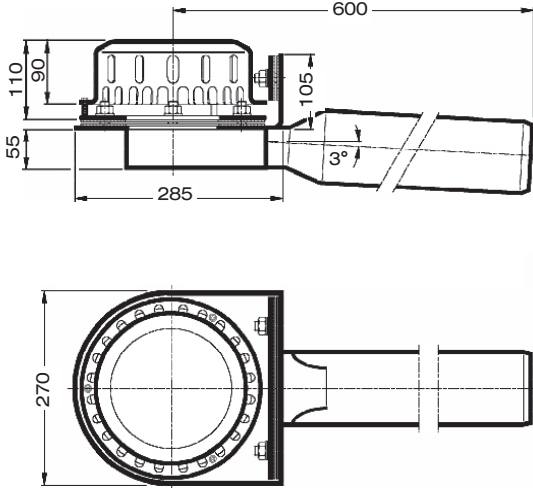
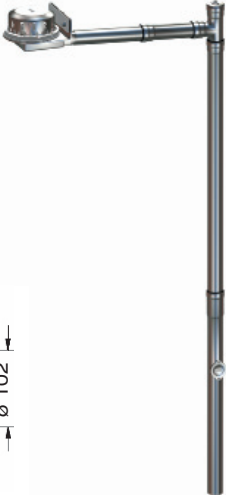
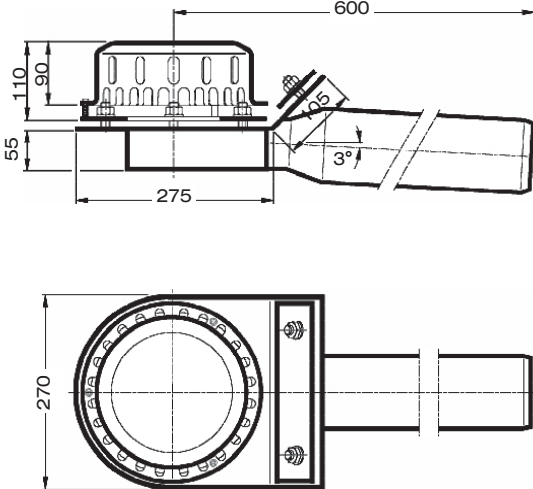
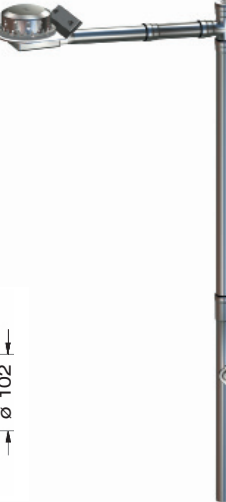
LX487-2X
 Drain Art.-No. 01360.100X
 Weight: 9,2 kg

Series 89
with roof penetration of 55 mm
 clamping flange 45°
 for bituminous roofing sheets

Heat tracing: Lorowerk recommends to check all drains and pipes with regard to their frost-sensibility. Where necessary, these parts should be upgraded with heat tracing.